

Review

THE APPLICATION OF DIGITAL AND ANALOG COMPUTERS TO THERMAL ANALYSIS

W. W. WENDLANDT

Department of Chemistry, University of Houston, Houston, Texas 77004 (U. S. A.)

(Received 6 June 1972)

ABSTRACT

The applications of digital and analog computers to problems in thermal analysis are reviewed. All of the applications are of a *passive* type in which there is no significant computer control of the experiment. Techniques discussed include thermogravimetry (TG), differential thermal analysis (DTA), differential scanning calorimetry (DSC), gas evolution analysis (GEA), and mass spectrometric thermal analysis (MTA).

INTRODUCTION

Although there are numerous applications of digital and analog computers to most chemical laboratory techniques^{5,3}, there have been relatively few applications to thermal analysis. All of the applications that have been described are of a *passive* type in which there is no significant computer control of the experiment. There have been no applications of the *active* type in which the computer is involved to some extent in the control of the instrument.

This review attempts to summarize the important applications of computers to thermal analysis techniques. Because of the difficulty in searching the literature for this type of information, no attempt has been made to write a comprehensive treatment of the subject. Rather, it is hoped that this review will include the more important investigations. For convenience, the discussion is divided into applications in thermogravimetry (TG), differential thermal analysis (DTA) and differential scanning calorimetry (DSC), and miscellaneous techniques.

THERMOGRAVIMETRY (TG)

One of the first applications of a digital computer to calculations of thermogravimetric data was that by Soulen¹. Since the amount of computation required to obtain kinetics constants from TG is large, a computer program was developed for the calculation of temperature, weight, and rate of reaction from the d.c. voltage

generated by the thermobalance. A Remington Rand Univac computer was used, employing a Math-Matic compiling system, in which a 23-sentence English language program was used to compute 60 values each of temperature, weight, cumulative weight-loss, and the rate of reaction, and to store these for subsequent computation of the kinetics constants. Instead of a data logging system, numerical values were manually taken from the strip-chart recordings at one minute intervals and used as input into the computer. It was stated that an English language program was rather inefficient for this type of program and that a more efficient program could no doubt be developed using machine language.

Almost all of the other applications of computers to thermogravimetry involved calculations pertaining to reaction kinetics. Schempf *et al.*² developed a program, POLY 2, for the determination of the pre-exponential factor of the Arrhenius equation and the activation energy. This program, designed to accept sample weight, w , and sample temperature, T , values as a function of time, t , was written for first-order reactions only, although with slight modifications it could be used for any order of reaction. It made use of a least squares polynomial fit of the time-sample weight values to the equation

$$w = \sum_{i=0}^n C_{(i+1)} t^{(i)} \quad (1)$$

where n is the desired order polynomial, C the coefficient of the polynomial and t the time. From the $w-t$ curve thereby generated, an additional Fortran subroutine, FREEB, calculated the reaction rate constant for any point on the TG curve using the equation

$$k = \frac{-\sum_{i=0}^{n-1} [i+1] C_{(i+2)} t^{(i)}}{\sum_{i=0}^n C_{(i+1)} t^{(i)}} = \frac{dw/dt}{w} \quad (2)$$

where n is the desired order polynomial. A least squares analysis of the values of $\log k$ versus $1000/T$ was obtained for the following first-order polynomial

$$\log k = \log A - Ea/2.303 R (1000/T). \quad (3)$$

The complete program is illustrated by the flow diagram in Fig. 1. The accuracy of the computer fit of the TG curve was 0.2 mg while the limit of accuracy for reading a weight value was 0.1 mg.

Two programs for the algorithmization of kinetic data computations from TG curves were developed by Sestak *et al.*³ They made use of the basic equation

$$dx/dt = \exp(-E/RT)(1-x)^n \quad (4)$$

where α is the degree of decomposition and n the order of reaction. The kinetics parameters, E , Z , and n , were evaluated by use of two differential methods. The first

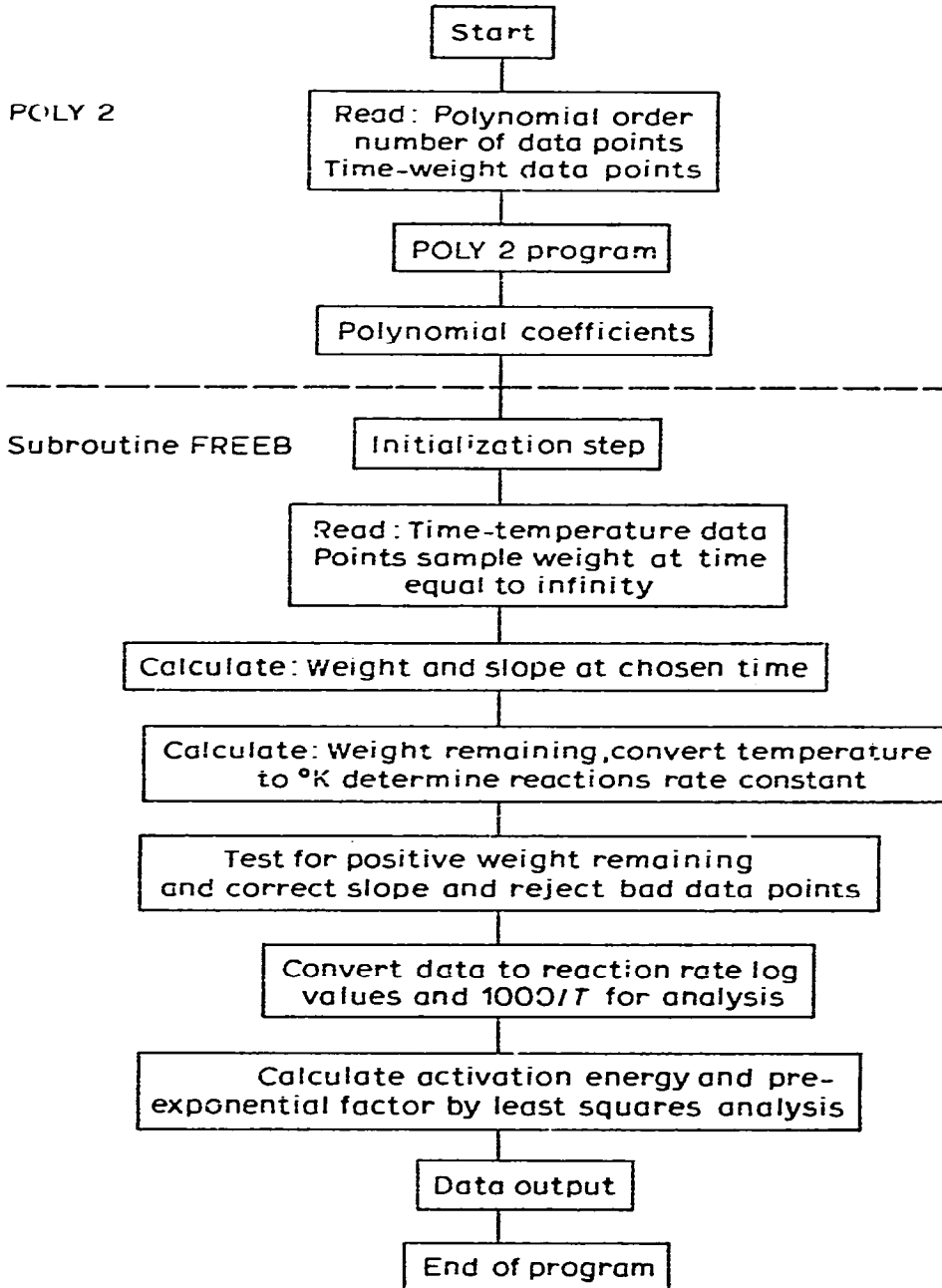

Fig. 1. Flow diagram for calculation².

method utilized a least squares polynomial fit of the TG curve with a j -th order polynomial

$$\alpha = A_0 + A_1 x + \dots + A_j x^j \quad (5)$$

where j is about 13 and A 's are constants obtained from the least squares fit of the

experimental data. The second method attempted to use the simplest means of obtaining a derivative of the observed TG curve by numerical derivation using the first three terms of the series

$$(dx/dt)_i = \{(w_{j+1} + w_{j-1})/2 - \dots + \dots + \dots\} / Qw_{\max} \quad (6)$$

where w is the weight loss and Q is a constant time interval of scanning. This program was written in ALGOL 60. The results obtained by computing data obtained from TG curves, with various programs and with those calculated manually, are shown in Table I. The discrepancies which occur were said to be due to differences in the requirements for the input data. A flow-chart for the second program used was also presented in detail.

TABLE I
COMPARISON BETWEEN MANUAL AND COMPUTER CALCULATIONS³

<i>Experimental data used</i>	<i>Manual results</i>			<i>Computer</i>	
	<i>Derivative⁴</i>	<i>Integral⁵</i>	<i>Freq. factor⁶</i>	<i>Program 1</i>	<i>Program 2</i>
CaC ₂ O ₄ → CaCO ₃ + CO(g) from ref. 4 $E = 74 \text{ kcal}, n = 0.7$	$E = 67 \pm 15$ $n = 0.6$	74.1 ± 3.5 1	74 1	72.1 1	58.67 0.591

Gallagher and his co-workers have described several TG data collection systems in which the data are obtained on magnetic tape or on punched paper tape. A block diagram of their first system⁷ is shown in Fig. 2. In this system, the outputs from the Cahn Model RG balance and the Chromel-Alumel thermocouple were converted to digital form and punched on paper tape for subsequent computer processing. The timing cycle for the counter was normally set to count the thermocouple channel for one sec and the weight channel for 99 sec. Switching time was relatively instantaneous and the data were punched while the counter is operating so that the dead time was negligible. The effective use of averaging each reading over these times leads to a reduction of noise which is important for the computation of the time derivative.

The digital data were transferred from punched paper tape to cards and the EMF versus temperature tables for the compensated thermocouple were fit by a least squares technique to the equation

$$^{\circ}\text{C} = 22.2877 + 25.7003 (\text{mV}) - 0.1050 (\text{mV})^2 + 0.0017 (\text{mV})^3 \quad (7)$$

which was satisfactory to $\pm 1^{\circ}\text{C}$ over the temperature region of 200° to 1000°C . A program was developed to compute the average temperature for each pair of consecutive temperature readings and associate this temperature with the average weight

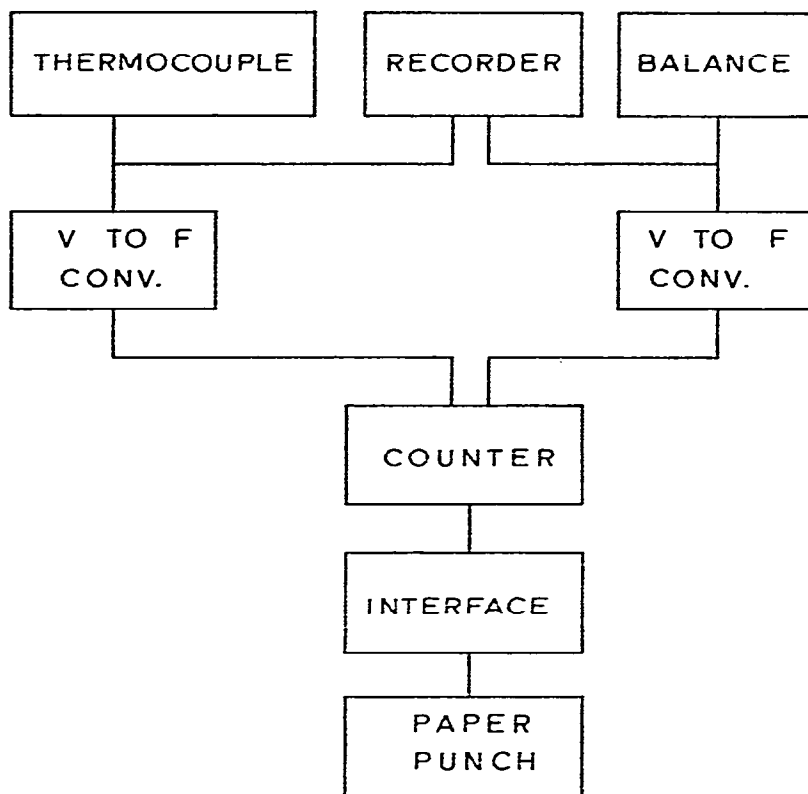

Fig. 2. Block diagram of digital TG system of Gallagher and Schrey⁷.

readings in the interval between the thermocouple readings. A General Electric Model 600 computer then tabulated and plotted both the percent weight-loss and the rate of weight-loss (mg/min) as a function of temperature. The rate of weight-loss was obtained from the difference in weight of consecutive readings (100 sec intervals) and corrected to give mg/min. No further refinement or smoothing of the differential data was necessary.

For isothermal measurements, using a Cahn Model RG thermobalance, the data acquisition system shown in Fig. 3 was employed^{11,12}. The system accepted up to four analog input signals in which two were used for weight and temperature, respectively. The voltages were converted to frequency using a voltage-to-frequency converter and four channels were simultaneously counted on four scalers for a predetermined time interval. The magnetic tape interface served as the control center. In the automatic mode, the data were scanned repeatedly at a preset time interval and placed on the magnetic tape along with channel identification numbers. A fifth channel could be created to insert a six digit number for labeling or control purposes. Data processing consisted of transferring the data from tape onto the disc storage of a Honeywell Model 635 Computer in appropriate arrays corresponding to each channel. Computer generated plots of each array as a function of time were then made with subsequent data processing as previously described¹².

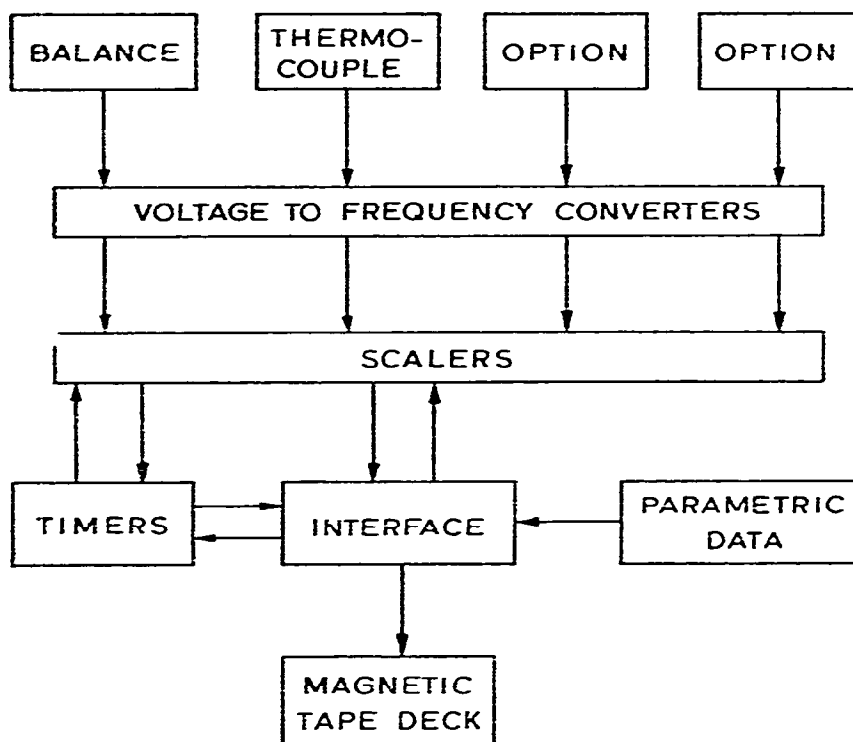
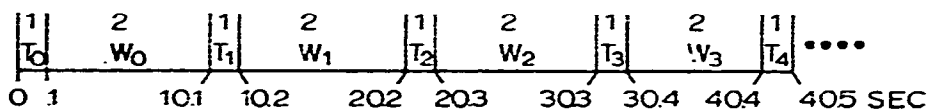

Fig. 3. Data acquisition system of Gallagher and Johnson^{11,12}.

Gallagher and co-workers^{8-10,13} also described a modification of the Perkin-Elmer thermobalance to obtain the data in digital form. In this instrument, the platinum furnace heater winding serves also as the temperature sensor. It forms one side of a bridge circuit while the other side is driven by the output voltage from the programming potentiometer. This same voltage is used to supply the temperature



PER CENT WEIGHT	°C	Mg/MIN	°C
$\frac{100 W_0}{W_0}$	$\frac{T_0 + T_1}{2}$	$\frac{60(W_0 - W_1)}{10.1}$	T_1
$\frac{100 W_1}{W_0}$	$\frac{T_1 + T_2}{2}$	$\frac{60(W_1 - W_2)}{10.1}$	T_2
$\frac{100 W_2}{W_0}$	$\frac{T_2 + T_3}{2}$	$\frac{60(W_2 - W_3)}{10.1}$	T_3

Fig. 4. Timing sequence employed by digital thermobalance⁸.

portion of the digital equipment and is directly related to temperature by use of magnetic (Curie point) TG calibration standards.

The two input voltages were converted to frequency and counted for a pre-determined time in the sequence as shown in Fig. 4. The temperature signal was counted for 0.1 sec and then automatically switched to the weight signal for 10 sec. The output data were constantly punched on paper tape for input into the computer.

The first stage in the computer processing of the punched tape data was to transfer the data to cards and to use these cards for the three steps in processing⁹. The first step was to obtain a graphical output of the weight as a function of time, as shown in Fig. 5. The second step of data handling consisted of utilizing the initial and

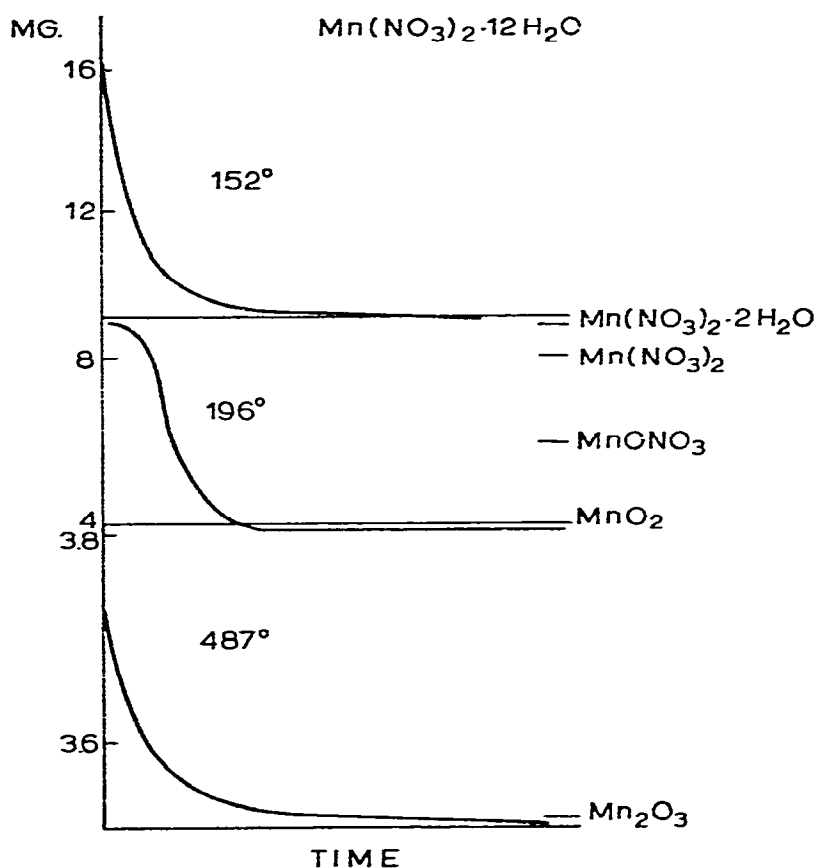

Fig. 5. Weight versus time curves as reported by Gallagher and Johnson⁹.

final weights for each interval to determine values of α , the fraction reacted. The computer, having calculated the values of α for each point then plotted these to conform to the eighteen equations given in Table II. Appropriate equations were determined by visual inspection of the computer output plots for their linearity. One such set of four curves for the plot of $-\ln(1-\alpha)$ versus time is shown in Fig. 6. The

TABLE II
KINETIC EQUATIONS USED IN THE COMPUTER ANALYSIS⁹

1. Power law	α^n ; $n = \frac{1}{3}, \frac{1}{2}, 1$ and 2
2. Contracting geometry	$1 - (1 - \alpha)^{1/n}$; $n = 2$ and 3
3. 2D Diffusion controlled	$(1 - \alpha) \ln(1 - \alpha) + \alpha$
4. Erofeev	$[-\ln(1 - \alpha)]^{1/n}$; $n = 1, \frac{3}{2}, 2, 3$ and 4
5. 3D Diffusion controlled	$(1 - \frac{3}{2}\alpha) - (1 - \alpha)^{2/3}$
6. Jander	$[1 - (1 - \alpha)^{1/3}]^2$
7. Prout-Thompkins	$\ln[\alpha/(1 - \alpha)]$
8. Second order	$\frac{1}{1 - \alpha} - 1$
9. Exponential	$\ln \alpha$

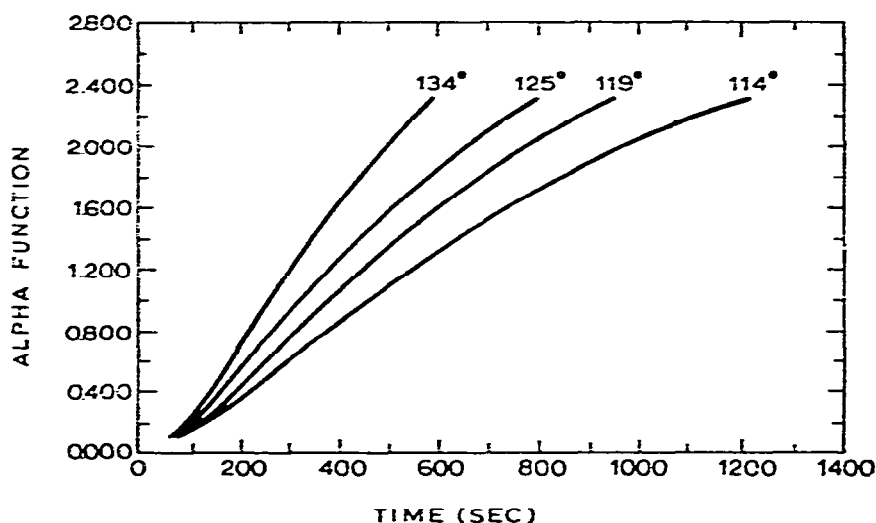

Fig. 6. Plots of $-\ln(1 - \alpha)$ versus time for the dehydrations of aqueous manganese(II) nitrate⁹.

choice of equation was then based on the exact degree of fit determined by the standard deviation arising from the calculation of k in the third stage of processing. This third stage consisted of the selection of the most likely kinetic equation or equations and the plotting of the best values of $\log k$ versus the reciprocal of the absolute temperature, and a least squares fit to determine the best straight line. The resulting activation energies, E , and the pre-exponential terms were printed out along with the plot.

Vachuska and Voboril²⁰ developed a program called VACHVO II²¹, for use on the GIER computer, in which the first-order and also the second-order derivations of the time dependencies of both sample weight and temperature are computed numerically with respect to time from experimental values of these quantities. A newer version of this program, denoted by the term VYRVACHVON²², in which a certain polynomial function is laid through the experimental points and its course is

determined by a least squares method. The computer then calculates the "corrected" input data from a given expressed function and using these data, numerically differentiates. Both programs were written in the GIER-ALGOL language.

Although the programs or techniques were not discussed in detail, a digital computer was used to analyze the kinetics data obtained from TG by a number of investigators¹⁴⁻¹⁹. One of these studies¹⁹ used a Hewlett-Packard Model 9100A programmable calculator.

Hughes and Hart²³ have developed an analog simulation program, BASE, which was used for the prediction of a TG curve. The calculation involved the plotting of the TG curve from the equation

$$f(\alpha) = \frac{A}{a} \int_{T_1}^{T_2} \exp\left(\frac{-E}{RT}\right) dt \quad (8)$$

where $f(\alpha)$ represents some description of the rate law for the fractional decomposition (α) of the solid; A is the pre-exponential factor; a is the heating rate (dT/dt) and E the activation energy. In order to write a patch diagram for the program, they put

$$y = \exp(-E/RT) = e^z \quad (9)$$

where $z = -E/RT$ and $dz = (E/RT^2)dT$. Then

$$dy = e^z dz \quad (10)$$

$$dy = e^z \left(\frac{E}{RT^2}\right) dT = 2.4 e^z \left(\frac{E}{RT^2}\right) dT \quad (11)$$

or

$$\dot{y} = 2.4 \exp\left(-\frac{E}{RT}\right) \frac{E}{RT^2} \quad (12)$$

Since the integral of \dot{y} is y and because $2.4 \exp(-E/RT) E/RT^2$ is identical with y , then it is assumed that $E/RT^2 y$, where $y = \exp(-E/RT)$ and generate $f(y)$ (i.e., $2.4y E/RT^2$), the integral of this function will be y . This process is represented by the patch diagram in Fig. 7. The computations were applied to the dehydration of

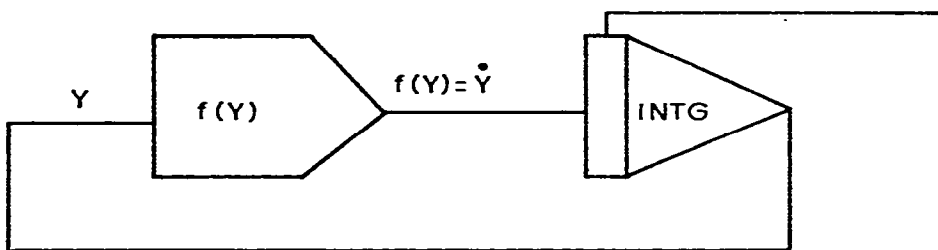

Fig. 7. Patch diagram of Hughes and Hart²³.

$\text{CaC}_2\text{O}_4 \cdot \text{H}_2\text{O}$, a system which has been well studied by a number of investigators. Using the data given by Freeman and Carroll⁴, the calculated and experimental curves are given in Fig. 8. It is interesting to note that the curve calculated by integrated methods using Akahira's tables and the experimental parameters gave a curve which coincided nicely with the computed one.

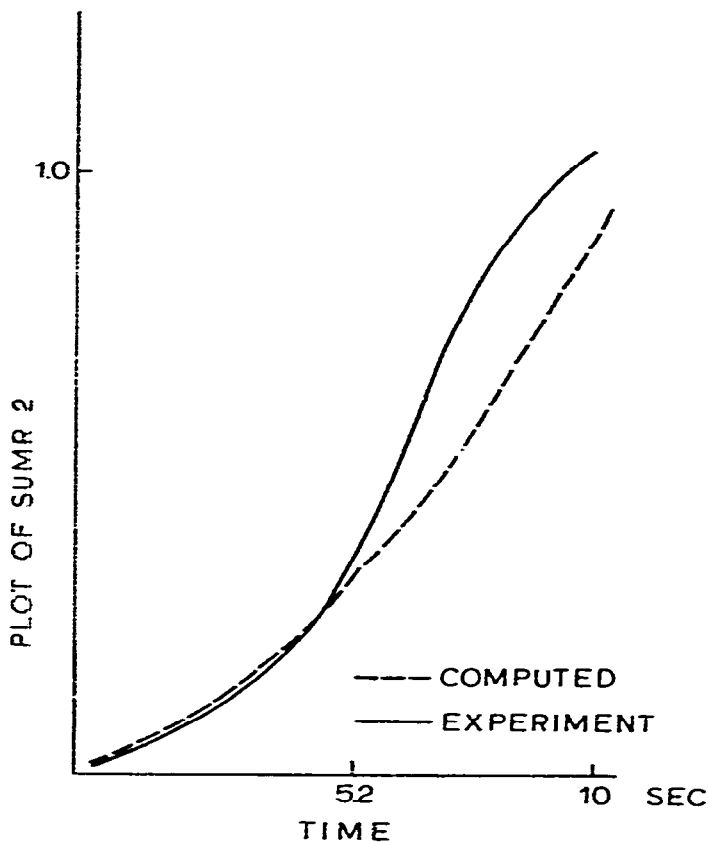

Fig. 8. Calculated and experimental TG curves for $\text{CaC}_2\text{O}_4 \cdot \text{H}_2\text{O}^{23}$.

The in-house differences between results for duplicate samples tested by different laboratories under supposedly similar conditions led to interest in the effects of the rate and mode of heating, and also of fluctuations in temperature after heating, on the weight-loss curves. Because these problems did not lend themselves to direct solution with the experimental equipment on hand, Gayle and Egger²⁴ applied analog computation to study the importance of these variables. The calculations were performed on an analog computer where the heating rate curves were programmed as the corresponding differential equations and the temperature integral of these used as input the Arrhenius equation. Integration of the latter provided the corresponding weight-loss curves. The treatment provided an estimate of the influence of constant thermal errors and of fluctuations about the programmed temperature level. It is noteworthy that symmetrical fluctuations did not result in a cancellation of errors

when the rate behavior was exponential rather than a linear function of temperature. The analog computer provided a graphic, reasonably accurate picture of the magnitude of such effects.

DIFFERENTIAL THERMAL ANALYSIS (DTA) AND DIFFERENTIAL SCANNING CALORIMETRY (DSC)

Nearly all of the computer applications to DTA have been concerned with the calculations of reaction kinetics; they also provide the ideal means of simulating the DTA curve of a chemical reaction of known kinetics. One of the first of these applications was that by Reed *et al.*²⁵ in which the quantitative determination of kinetics by the methods of Borchardt and Daniels²⁶ and Kissinger²⁷ were evaluated and compared. The DTA curve was generated numerically by use of equations such as

$$-\theta_r' \left(\frac{d\psi}{d\theta_r} \right) = \zeta \psi^n e^{-\varepsilon/\theta} \quad (13)$$

where ε is the activation energy and $\theta_r'(d\psi/d\theta_r)$ the reaction order, ψ is N/N_0 (number of moles), $\zeta = \alpha A (N_0/V)^{n-1}$, and θ_r' is the dimensionless heating rate; in finite-difference form

$$\psi(\theta_r) - \psi(\theta_r + h) = \frac{h\zeta}{\theta_r'} \left[\frac{\psi(\theta_r + h) + \psi\theta_r}{2} \right]^n \exp [-2\varepsilon/\theta(\theta_r + h) + \theta(\theta_r)] \quad (14)$$

where h represents the mesh spacing, $\Delta\theta_r$. A typical computer generated curve, in which the effect of activation energy, ε , on the DTA curve is plotted, is shown in

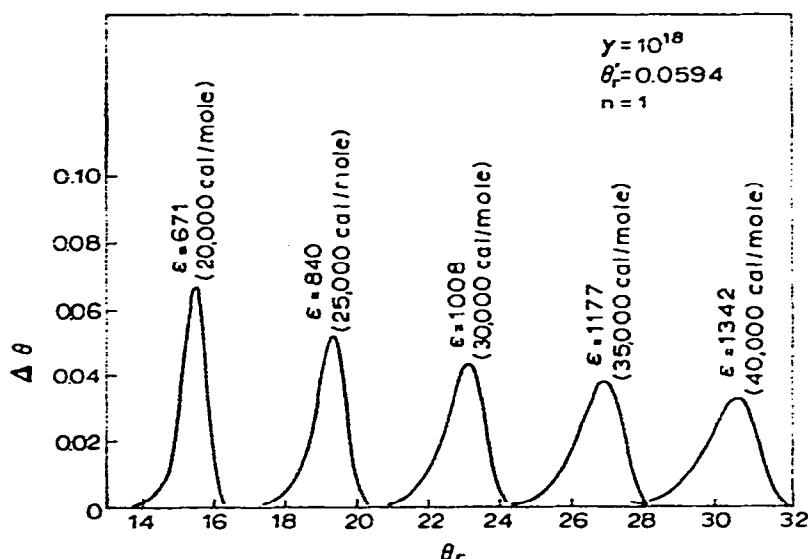

Fig. 9. Effect of activation energy on DTA curve²⁵.

Fig. 9. Both the location and the shape of the curves are affected, but the dependence is inverse to that observed for the changes of the frequency factor.

The fraction of sample decomposed (α) from DTA curves was calculated by an algorithm in ALGOL 60 language for a NCR Elliot Model 4130 computer by Skvara and Satava²⁸. This algorithm calculated α and $\log g(\alpha)$ and plotted the latter as a function of temperature. Comparison of the computed DTA data with the experimental values for several dissociation reactions indicated a good agreement and applicability of the method.

The use of a systems analog to improve the performance of a DTA apparatus and also to study the thermal effects in the DTA curve was investigated by Wilburn *et al.*^{29,30}. A finite-difference procedure was used to relate the thermal gradients within the samples and to generate or absorb heat according to a known equation. The influence of such physical properties on the shape and peak temperature of a typical DTA curve was calculated on an ICT Model 1909 computer.

The application of computer calculations to DTA studies of the crystallization kinetics of polymers was described by Gornick⁵⁴. Calculations were made of the temperature of a polymeric sample during the cooling process using a Burroughs Model 5500 computer. Morie *et al.*⁵⁵ used an IBM Model 1130 computer to prepare standard vapor pressure plots of $\ln P$ versus $1/T$, the vapor pressure data being obtained from DTA or DSC curves. The heat of vaporization was calculated by the Haggemacher method as modified by Fishtine.

David *et al.*³¹ used a digital temperature readout device in conjunction with an analog recorder for transition temperature measurement in DTA. No computations were made, however, on the temperature measurements although temperature resolution was about 0.05°C at a heating rate of $10^\circ\text{C}/\text{min}$.

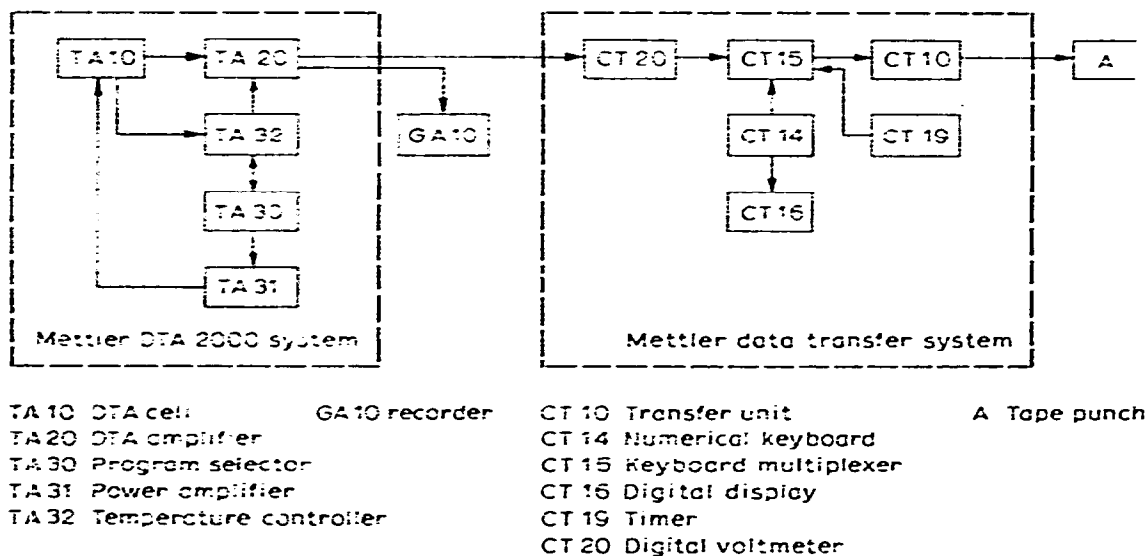

Fig. 10. Mettler data transfer system connected to a Mettler DTA 2000 system³².

Amstutz³² described the Mettler data acquisition system which is capable of handling 8-digit numbers of any format type or voltage level. A schematic diagram of the system is shown in Fig. 10. Expansion capabilities include digital and analog multiplexers, keyboards and switch banks for manual entry of data, timers, and programmers. Applications to DTA include off-line recording of raw data on punched paper tape or magnetic tape, and on-line processing, ranging from simple peak area calculations by means of programmable desk-top calculators to the more complex numerical determinations of heat or reaction, kinetics, and purity analysis.

One of the major applications of computers to differential scanning calorimetry (DSC) is in the determination of the purity of organic and inorganic compounds. The precision and accuracy of purity determinations by this technique have been reviewed by Joy *et al.*³³. One of the first programs for purity determinations using DSC data was that developed by Driscoll *et al.*³⁴. Required input data are the sample mass and molecular weight, instrument constants, a reference temperature at a point where the curve is still on the base line, and ordinate and abscissa measurements on the curve. One measurement should be at the melting curve peak, but the intervals need not be of uniform size. A maximum of 99 pairs of readings can be accommodated by the program.

The program divides the curve into 99 equal temperature intervals and integrates to obtain the ΔH_f . Temperature correction and baseline area correction are determined for each interval and the partial area is calculated. The program then applies successive one-half percent area corrections on each partial area and the total area and calculates the $1/F$ values. A least squares regression analysis is used in each corrected line until a minimum standard deviation of the points about the calculated line is reached. The "best values" is then used in the subsequent calculations. Output from the computer includes the ΔH_f , T_0 , T_m , mole percent impurity, the $1/F$ limits used, the percent correction applied, and the cryoscopic constant. A corrected mole percent impurity assuming solid solution behavior is also calculated. The "linearization" of the T versus $1/F$ curve has been discussed³⁵. Joy *et al.*³³ rewrote the above program from Fortran into a basic program operable on a time-shared computer terminal. Other DSC purity determination programs have been developed by Barrall and Diller³⁶ and Scott and Gray³⁷.

Using an IBM Quiktran program, Ellerstein³⁸ performed calculations of DSC curve data from the equation

$$\frac{\Delta \log l}{\Delta \log A_r} = \frac{E}{2.303 R} \frac{[\Delta(1/T)]}{[\Delta \log A_r]} + n \quad (15)$$

where l is the ordinate displacement between the base line and curve and A corresponds to the area remaining at temperature T . Plotting the left-hand side versus the bracketed expression gives a curve whose slope is $E/2.303 R$ and the intercept will be equal to n , the order of reaction. Results from the Quiktran program are then fed into an IBM Quiktran common library program (FITLIN) which gives a "best" line fit of the calculated points.

Gray³⁹ developed a program which accepts the DSC sample and baseline data, matches the "isothermal", performs cumulative and total area integrations in units of cal/g, corrects the temperature for thermal lag, and tabulates and plots ordinate values in specific heat units as well as cumulative area in enthalpy units. The analog data from the DSC instrument are digitized and transferred to paper tape with the use of the Perkin-Elmer ADS VI Analytical Data System for Thermal Analysis. The data are digitized every two seconds or every 0.133 degree. A computer plotter then plots the DSC curve and also the cumulative peak area in specific enthalpy units, cal/g.

Crossley *et al.*⁴⁰ used a computer reduction technique for the DSC isothermal curve which was developed to replace the use of a planimeter. The data reduction was divided into two phases: (a) mechanism independent solutions for the reactant fraction, α , and various functions of α (where α is the reactant fraction remaining at time, t) and (b) solutions for mechanism dependent rate constants. For the first phase, the DATAR program was developed which consisted of the following: Ordinal points, referred to as "coarse data", and evenly spaced in time over the time span of the DSC curve, are read directly into the computer. Up to 1000 points may be read, but 40-50 are usually sufficient for acceptable accuracy. The resultant fraction remaining at time, t , is calculated by the equation

$$\alpha(t) = \frac{\int_0^t (\text{ORD}) dt}{\int_{t_{max}}^t (\text{ORD}) dt} \quad (16)$$

A Simpson's Rule procedure modified to handle odd numbers of intervals was used to calculate the integrals. The program calculates and prints the time in sec and in min, α , $\ln \alpha$, 100α , $1/\alpha$, $1/\alpha^2$, $(1-\alpha)\alpha$, and $\log 100[(1-\alpha)/\alpha]$. For the second stage, the PARACT program was used to determine the true rate constants, k_1 and k_2 .

Other programs which can be used to calculate reaction kinetics from DSC data are by Kauffman and Beech⁴¹ and Rogers and Smith⁴². Heuvel and Lind⁴³ used a computer to correct DSC data for effects due to thermal lag and heat capacity changes while Sondack⁴⁴ developed a simple equation for linearization of data in DSC purity determinations.

MISCELLANEOUS THERMAL TECHNIQUES

Analysis of isoperibol calorimetric data requires lengthy graphical procedures and/or tedious calculations to obtain corrected resistance changes for the reaction and calibration experiments. The reaction experiment graphically resolves into two linear portions, the initial rating period (IRP), and the final rating period (FRP), connected by a curve for which no analytical equation is known. A program was developed for these calculations by Gayer and Bartel⁴⁵.

Friedman and co-workers⁴⁶⁻⁴⁸ have developed a digital converter for recording

evolved gas analysis (EGA)-mass spectrometric (MS) data on punched paper tape. The data collection system is shown in Fig. 11. It is based on a very stable programmed power supply that steps the gate to preselected discrete ionic mass peak locations. In practice, analog gate voltages are determined for about 20 peak centers from m/e 1 to about 203, as monitored by a digital voltmeter. These are then analyzed

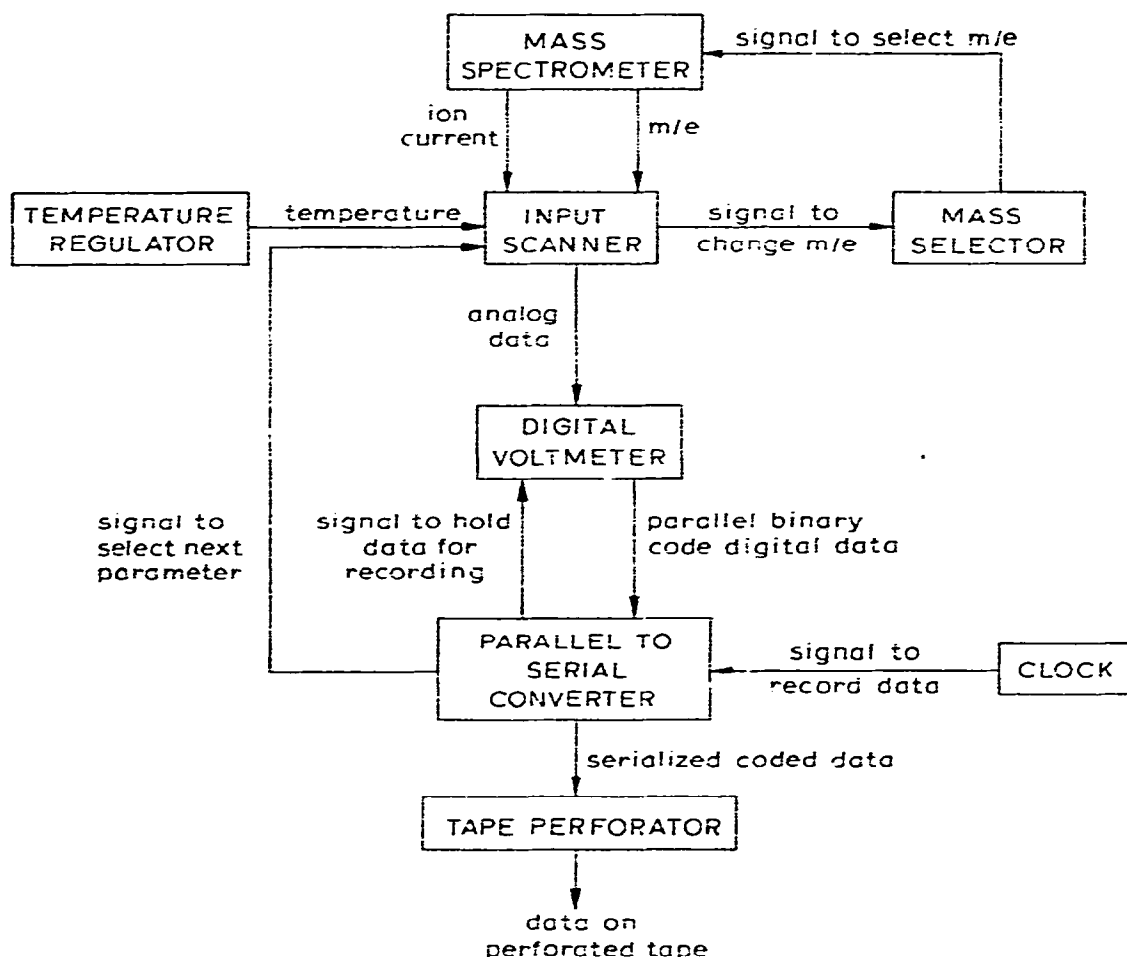

Fig. 11. Data collection system for EGA-MS after Friedman *et al.*⁴⁷.

by a least squares shared-time program using a polynomial equation that includes five constants. If all of the calculated points are within values equivalent to 10 nanosec of the observed time delay, the fit is accepted and a print-out is obtained for all analog gate voltages as a function of mass number, by interpolation and extrapolation. The punched paper tapes generated during a run are read by an optical reader and stored in a small computer. A large computer then sorts the data by mass number and plots the data on a graphic plotter. The plotted data are corrected for background, instrument sensitivity, editorial corrections, and are normalized to 1 mg initial sample weight.

Gibson⁴⁹ described a TG-MS system which contained a PDP 8/L computer interfaced to the mass spectrometer for on-line control of the mass spectral data. A schematic diagram of the system is shown in Fig. 12. The output analog signal from the mass spectrometer is integrated and converted to digital form by a 12-bit con-

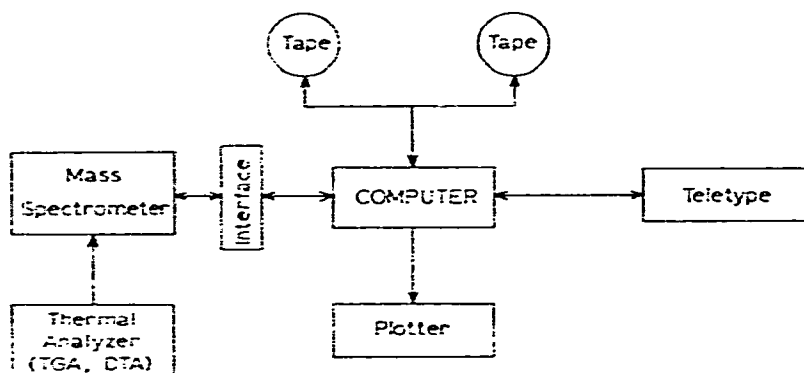

Fig. 12. TG-MS computer system after Gibson⁴⁹.

verter and transfers it to magnetic tape. Two separate modes are possible: (1) data logging and (2) spectrum control; they differ only in the manner in which they acquire data. During operation of the mass spectrometer, the plotter gives a real-time gas release curve, which is simply a plot of the ion current from the electron multiplier at each recorded spectrum scanned. Other output routines include:

- (1) Reconstruction of a gas release pattern which normalizes the largest gas release peak or region to 100 and indexes the mass spectra during the run.
- (2) Printed or plotted spectra from any mass spectrum collected.
- (3) Plots of individual mass (*e.g.*, $m/e = 18$) peaks as a function of temperature.
- (4) Spectrum plots or printouts with positively identified mass scales and numeric ion intensities.
- (5) Spectrum plots or printouts with the background spectra subtracted to eliminate the effect of contaminants or backgrounds.

The TG and gas release curves of a sample of Apollo 15 rille soil is shown in Fig. 13. The individual m/e curves were automatically plotted.

Kinetics calculations on poly(methylmethacrylate) using mass spectrometric thermal analysis (MTA) were described by Sakamoto *et al.*⁵⁶. Using the activation energy calculated from the experimental data, the computer plots the logarithm of the reduced rate, $dc/d\theta$ versus the logarithm of the reduced time, θ . A comparison is then made between these curves which are calculated for various reaction mechanisms, and the curve which fits best is that of the first order reaction.

Ingraham⁵⁰ used samples pelletized into a specific geometry for convenience in computer calculations of the kinetics results.

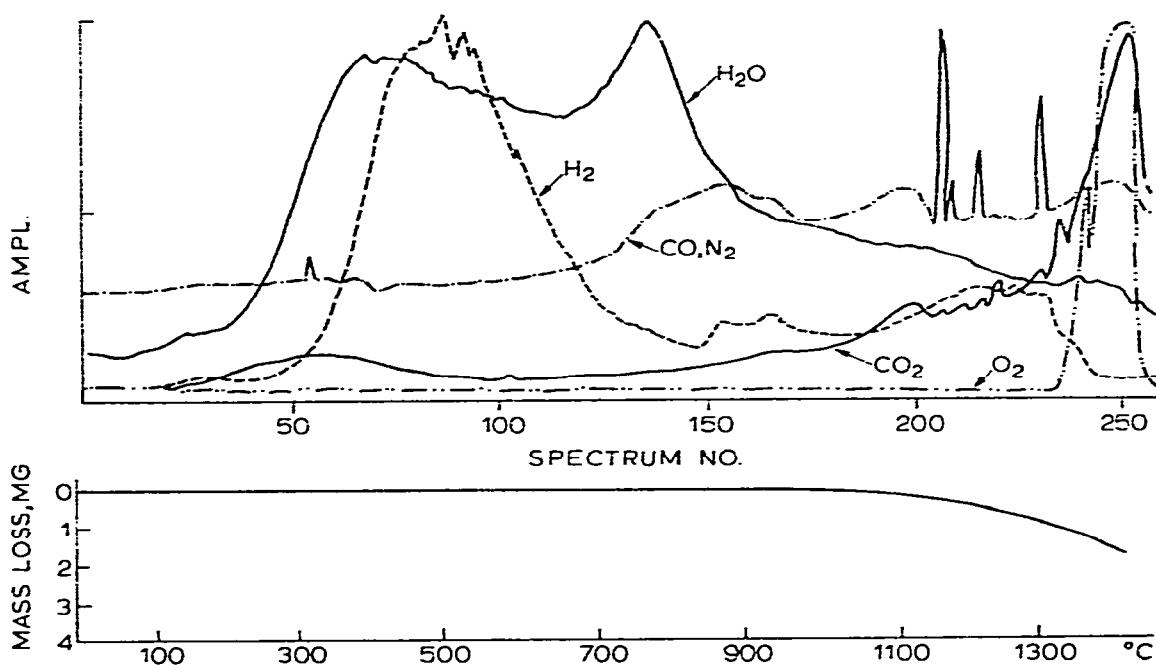

Fig. 13. TG and gas release curves of Apollo 15 rille soil after Gibson⁴⁹.

Pfeil⁵¹ discussed the application of digital computers to the statistical analysis of the TG measurements of edema. Computer graphics can also provide a useful and much-needed service in the thermal analysis of biological systems.

It should be noted that computer data acquisition systems for thermal analysis instruments are available from the Perkin-Elmer Corporation³⁷, the DuPont Company, and the Mettler Instrument Company³². A data acquisition system for a thermal analyzer has also been described by Yui *et al.*⁵².

ACKNOWLEDGEMENT

The support of this work by the Robert A. Welch Foundation of Houston, Texas, is gratefully acknowledged.

REFERENCES

- 1 J. R. Soulen, *Anal. Chem.*, 34 (1962) 136.
- 2 J. M. Schempf, F. E. Freeburg, D. J. Roger and F. M. Angeloni, *Anal. Chem.*, 38 (1966) 520.
- 3 J. Sestak, A. Brown, V. Rihak and G. Berggren, in R. F. Schwenker and P. D. Garn (Eds.), *Thermal Analysis*, Academic Press, New York, Volume 2, 1969, p. 1035, 1085.
- 4 E. S. Freeman and B. Carroll, *J. Phys. Chem.*, 62 (1958) 394.
- 5 A. W. Coates and J. P. Redfern, *Nature*, 201 (1964) 88.
- 6 V. Satava and J. Sestak, *Silikaty*, 8 (1964) 134.
- 7 P. K. Gallagher and F. Schrey, in R. F. Schwenker and P. D. Garn (Eds.), *Thermal Analysis*, Academic Press, New York, Volume 2, 1969, p. 929.
- 8 F. K. Gallagher and F. Schrey, *Thermochim. Acta*, 1 (1970) 465.

- 9 P. K. Gallagher and D. W. Johnson Jr., *Thermochim. Acta*, 2 (1971) 413.
- 10 P. K. Gallagher and D. W. Johnson Jr., *Thermochim. Acta*, 3 (1972) 303.
- 11 P. K. Gallagher and D. W. Johnson Jr., *Thermochim. Acta*, 4 (1972) 283.
- 12 D. W. Johnson Jr. and P. K. Gallagher, *J. Phys. Chem.*, 75 (1971) 1179.
- 13 P. K. Gallagher, F. Schrey and B. Prescott, *Thermochim. Acta*, 2 (1971) 405.
- 14 T. Ozawa, *J. Thermal Anal.*, 2 (1970) 301.
- 15 J. Zsako, *J. Phys. Chem.*, 72 (1968) 2406.
- 16 J. Zsako, C. Varhelyi and M. Agosescu, *Studia Babes-Bolyai Univ.*, 2 (1970) 33.
- 17 J. Zsako, *Studia Babes-Bolyai Univ.*, 2 (1970) 113.
- 18 J. H. Sharp and S. A. Wentworth, *Anal. Chem.*, 41 (1969) 2060.
- 19 L. Reich, W. Gregory and S. S. Stivala, *Thermochim. Acta*, 4 (1972) 493.
- 20 J. Vachuska and M. Voboril, *Thermochim. Acta*, 2 (1971) 379.
- 21 J. Vachuska and N. Rykalova, *GIER Computer Library, NRI, Czech. Acad. Sci.*, No. 1064.
- 22 N. Rykalova and J. Vachuska, *GIER Computer Library, NRI, Czech. Acad. Sci.*, No. 1399.
- 23 M. A. Hughes and R. Hart, *ICTA III*, Davos, Switzerland, August 23–28, 1971, paper No. I-21.
- 24 J. B. Gayle and C. T. Egger, *Anal. Chem.*, 44 (1972) 421.
- 25 R. L. Reed, L. Weber and B. S. Gottfried, *Ind. Eng. Chem., Fundam.*, 4 (1965) 38.
- 26 H. J. Borchardt and F. Daniels, *J. Amer. Chem. Soc.*, 79 (1957) 41.
- 27 H. E. Kissinger, *Anal. Chem.*, 29 (1957) 1702.
- 28 F. Skvara and V. Satava, *J. Thermal Anal.*, 2 (1970) 325.
- 29 F. W. Wilburn, J. R. Hesford and J. R. Flower, *Anal. Chem.*, 40 (1968) 777.
- 30 R. Melling, F. W. Wilburn and R. M. McIntosh, *Anal. Chem.*, 41 (1969) 1275.
- 31 D. J. David, D. A. Ninke and B. Duncan, *Amer. Lab.*, January (1971) 31.
- 32 D. Amstutz, *ICTA III*, Davos, Switzerland, August 23–28, 1971, paper I-39.
- 33 E. F. Joy, J. D. Bora and A. J. Barnard, *Thermochim. Acta*, 2 (1971) 57.
- 34 G. L. Driscoll, I. N. Duling and F. Magnotta, in R. S. Porter and J. F. Johnson (Eds.), *Analytical Calorimetry*, Plenum Press, New York, Volume 1, 1968, p. 271.
- 35 G. L. Driscoll, I. N. Duling and F. Magnotta, *Sun Oil Quart.*, 3 (1969) 24.
- 36 E. M. Barrall II and R. D. Diller, *Thermochim. Acta*, 1 (1970) 509.
- 37 L. R. Scott and A. P. Gray, *Perkin-Elmer Instrum. News*, 19 [3] (1969) 1.
- 38 S. M. Ellerstein, in R. S. Porter and J. F. Johnson (Eds.), *Analytical Calorimetry*, Plenum Press, New York, Volume 1, 1968, p. 279.
- 39 A. P. Gray, *Perkin-Elmer Instrum. News*, 20 (1969) 8.
- 40 R. W. Crossley, E. A. Dorko and R. L. Diggs, in R. S. Porter and J. F. Johnson (Eds.), *Analytical Calorimetry*, Plenum Press, New York, Volume 2, 1970, p. 429.
- 41 G. B. Kauffman and G. Beech, *Thermochim. Acta*, 1 (1970) 99.
- 42 R. N. Rogers and L. C. Smith, *Thermochim. Acta*, 1 (1970) 1.
- 43 H. M. Heuvel and K. C. J. B. Lind, *Anal. Chem.*, 42 (1970) 1044.
- 44 D. L. Sondack, *Anal. Chem.*, 44 (1972) 888.
- 45 K. H. Gayer and J. Bartel, *Thermochim. Acta*, 3 (1972) 337.
- 46 H. L. Friedman, *J. Macromol. Sci.*, A1 (1967) 57.
- 47 H. L. Friedman, G. A. Griffith and H. W. Goldstein, in R. F. Schwenker and P. D. Garn (Eds.), *Thermal Analysis*, Academic Press, New York, Volume 1, 1969, p. 405.
- 48 H. L. Friedman, *Thermochim. Acta*, 1 (1970) 199.
- 49 E. K. Gibson Jr., *Thermochim. Acta*, 5 (1973) 243.
- 50 T. R. Ingraham, in H. G. McAdie (Ed.), *Proc. Second Toronto Symposium on Thermal Analysis*, Chemical Institute of Canada, Toronto, 1967, p. 21.
- 51 R. W. Pfeil, in H. G. McAdie (Ed.), *Proc. Third Toronto Symposium on Thermal Analysis*, Chemical Institute of Canada, Toronto, 1969, p. 187.
- 52 H. Yui, R. Kato, H. Okamoto and A. Maezono, *7th Japanese Calorimetry Conference*, November 25–26, 1971, Nagoya, Japan.
- 53 S. P. Perone, *Anal. Chem.*, 43 (1971) 1288.
- 54 F. Gornick, *J. Polym. Sci., Part C*, 25 (1968) 131.
- 55 G. P. Morie, T. A. Powers and C. A. Glover, *Thermochim. Acta*, 3 (1972) 259.
- 56 R. Sakamoto, T. Ozawa and M. Kanazashi, *Thermochim. Acta*, 3 (1972) 291.